

## ACTIVITY 1B

# Energy Diagrams --- Attraction

### **Goal**

Changes in energy are a good way to describe an object's motion. Here you will construct energy diagrams for a low friction cart and learn how these diagrams can be useful. This technique will prepare you for similar uses of energy diagrams in quantum physics.

In general terms physics can be divided into two broad categories - classical physics and modern physics. When we use modern physics to explain a phenomenon, we are using concepts that trace their origin to the quantum revolution that began in the early part of the 20<sup>th</sup> century. Classical physics is everything else. These two branches of physics share many concepts such as energy, momentum, forces, and conservation laws. They differ fundamentally in the concepts and models, which are used to describe the very small.

To gain understanding of the processes taking place at atomic and subatomic levels, you need the help of quantum mechanics. The objective of the *Visual Quantum Mechanics* units is to introduce you to some aspects of this relatively new way of thinking and, thus, to learn how we know about very small objects such as atoms and molecules.

In quantum mechanics the concept of energy is frequently used to help us describe events and motion. Instead of describing changes in motion in terms of forces and accelerations, we use changes in energy. A convenient way to describe changes in energy is to sketch a graph of the value of an object's energy at various locations. When we create such a graph for energy, we call it an *energy diagram*.

Using energy to describe motion is somewhat different from the typical approach. However, it is a very powerful technique that can be used for both small and large objects.

To prepare you for learning about atoms and other small objects you will first describe the motion of a cart using potential energy diagrams. You will see that you will be able to describe the motion of a moving object without actually seeing that object or its motion. All you need to know is the energy.

An example of a *potential energy diagram* is shown in Figure 1-1. On the horizontal axis is the location of the cart while the vertical axis shows the value of the potential energy at each location. It shows us how the potential energy changes along the path of the cart. The potential energy is highest for locations between 0 and 0.1 meters, is zero from 0.1 to 0.2 meters, and rises to an intermediate value for 0.2 to 0.3 meters. We shall see we can learn a lot about the cart's motion from this diagram.

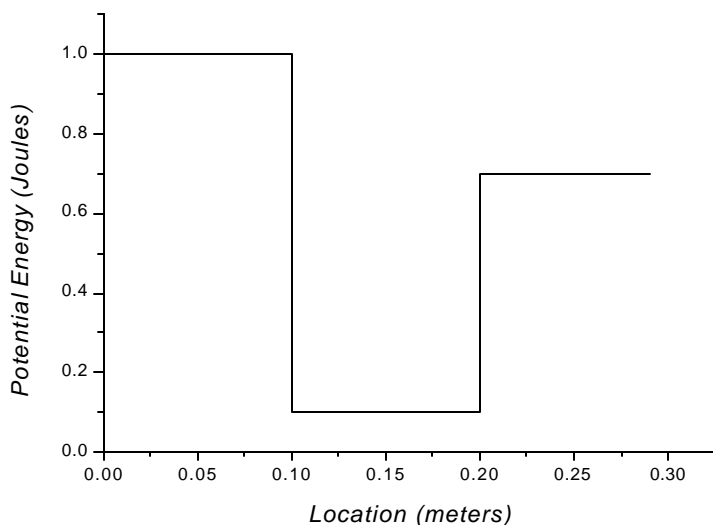

Figure 1-1: A potential energy diagram for a cart.

The potential energy varies with the location of the object. This energy can arise from a variety of interactions including elastic, gravitational, chemical, etc. In this unit, the potentials are generated with the help of magnets. However, the interactions between atoms and nuclei are of different origin. Therefore, the comparison with the atom that you will attempt later on will only be concerned with the shape of the potential energy curve, not with the origin of the interactions.

In these activities you will arrange magnets along a track and observe the interaction between these magnets and a magnet on the cart. By changing configurations of the magnets along the track you will obtain potential energy diagrams of various shapes. In this activity you will arrange the magnets in *attractive* mode.

Throughout this set of activities you will use relatively low-friction systems. The carts will move on either very low-friction wheels and a track or on a cushion of air. In sketching graphs and discussing results we will assume that we can ignore any losses to friction.

In this activity we will frequently make approximate sketches of the energy of the cart. As a first example, consider what happens when you push the cart along the track with no magnets near the track or on the cart. Try it now by giving the cart a gentle push.

? Use your observation of the motion and sketch a graph of speed vs. location. Your graph should be just a rough sketch. We do not measure the values of the speed, so we can only approximate the shape of the graph.

? Now, sketch a rough graph of the kinetic energy vs. location. (Hint: The kinetic energy is proportional to speed<sup>2</sup>.)

Again, we have not measured the kinetic energy, so we can not put values on the vertical axis, but we can learn a lot from the shape of the curve. Your curve probably shows that the kinetic energy stays approximately the same value with distance as it moves along the track. That is no surprise. With very little friction the energy of the cart will not change.

Here we have included interactions with the ends of the track. At the ends the speed decreases momentarily to zero as the cart changes direction. A sketch of kinetic energy vs. location is shown in Figure 1-2.

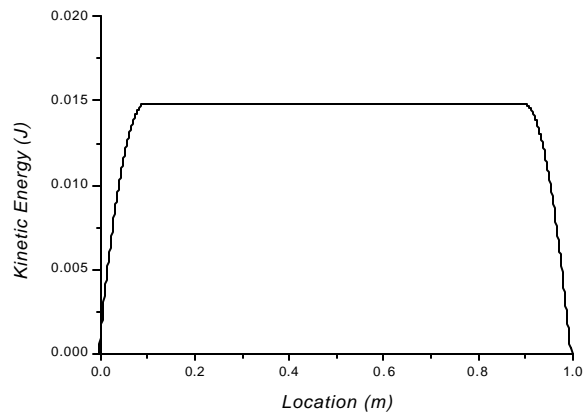

Figure 1-2: A graph of kinetic energy vs. distance for a cart that loses none of its energy to friction. It only interacts with the ends of the track.

Think about the graph of the total energy of the cart when it is moving on a level track. Because we ignore the effect of friction, the total energy (total energy = potential energy + kinetic energy) will not change. The total energy will not vary even at the ends of the track. Thus, the graph will look like Figure 1-3.

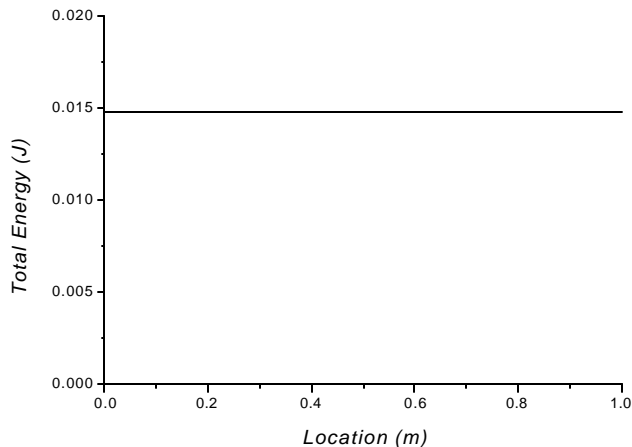

Figure 1-3: The graph of total energy vs. distance for a cart experiencing no friction and traveling on a level track.

We can draw this graph because the total energy of the cart at every point along the track is equal to its kinetic energy when no interactions are present. So far you constructed the energy diagram of the cart, when no magnets are present.

## Exploring interactions between attractive magnets

The diagram below shows you how to set up the experiment:

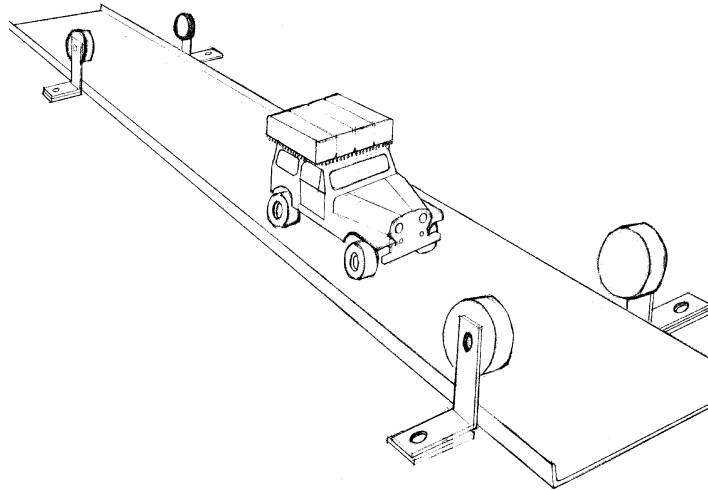

Figure 1-4: The experiment arrangement for the cart interacting with magnets.

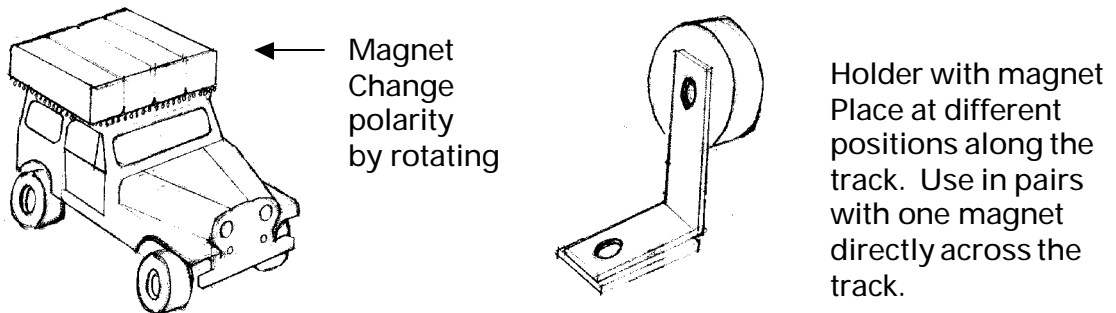

Figure 1-5: A cart with a magnet and a magnet holder.

Now we will add interactions to our cart. The interactions will occur between magnets on the cart and magnets along the track.

Push the cart and watch carefully as it goes through the magnets. If the cart does not go beyond the magnets, try again with a stronger push.

? How did the speed of the cart change as it approached and then passed the magnets? Write down your observations about all speed changes.

? In the space below, draw a rough sketch of the speed changes vs. location and then kinetic energy vs. location.

? Indicate the location of the magnets on your diagram.

The change in kinetic energy near the magnets shows that the kinetic energy becomes greater than the total energy. However, we know that energy is conserved. Thus, another form of energy must also change in the region near the magnets to keep the total energy constant. This other energy is the potential energy resulting from the magnetic interactions. We can use information about the kinetic and total energy of the cart to construct a potential energy diagram of the cart-magnet system. To construct a graph of a potential energy vs. location, use potential energy = total energy - kinetic energy. In the present case we must just approximate because we do not have exact values.

? Sketch the potential energy diagram of the cart by subtracting it from the kinetic energy diagram.

To maintain conservation of energy the potential energy must be negative in the region near the magnet. In fact, the shape of the potential and kinetic energy diagrams turned out to be identical, although inverted. If we add up the dip of the potential energy and the hump of the kinetic energy together, they will cancel out. The resulting diagram will be a straight line. This line represents the total energy of the cart that does not change if friction is not present.

The graphs of potential energy vs. location that you created are examples of *potential energy diagrams*. These diagrams can be useful in describing motion for all types of objects. Once you have the potential energy diagram for a situation, you can describe the motion of an object.

The usual method of using potential energy diagrams is to:

- start with the physical situation
- use the physics to draw the potential energy diagram
- describe the motion

In this way you can describe the motion even when you have never seen it. We can also describe other features in addition to speed and acceleration. In later activities we will look at some of those features.

The potential energy diagram provides an alternative way to describe motion of objects such as carts. They can also be used for analyzing the motion of very small objects — ones we cannot see. Thus, we need to understand first their value for objects we can see before using them with objects that are too small to see.

## Homework Assignment

1. A friend of yours has set up a very low friction cart and magnets and sketched the kinetic energy diagram in Figure 1-6.

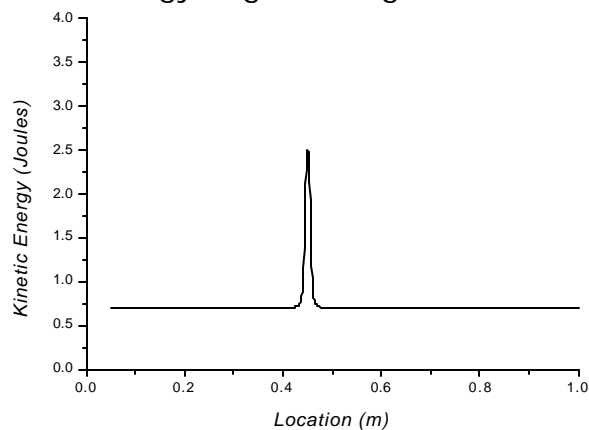

Figure 1-6: A kinetic energy diagram.

Interpret the diagram by answering the following questions:

- Indicate the location of the magnets in terms of meters along the track.
- How is the speed of the cart changing (increasing, constant, decreasing) as it moves from .3 m to .4 m, from .4 m to .5 m, and from .5 m to .6 m?
- What is the value of the *potential* energy at point  $x = .35$  m and at  $x = .45$  m.?
- Sketch the potential energy for this situation.



2. Figure 1-7 shows two potential energy diagrams for arrangements of carts and magnets.

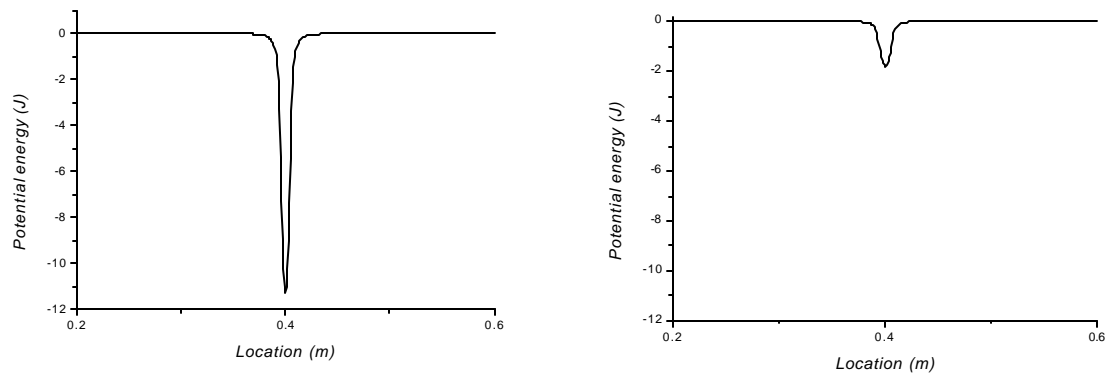

Figure 1-7: Two potential energy diagrams involving carts and magnets.

Both diagrams are drawn to the same scale. Answer the following questions based on these diagrams:

- Sketch kinetic energy diagrams for each situation.
- For which situation is the attraction between the cart and magnets greater?
- For which situation does the interaction occur over a greater distance?